

OPEN FRAME HAND CRIMP TOOL HX4

DMC DANIELS
MANUFACTURING
CORPORATION
DATASHEET

THIS HAND TOOL MUST NOT BE USED IN ANY POWERED "PRESS" AS DEFINED BY OSHA AT CFR 1910.211 (46)

SEE REVERSE SIDE FOR IMPORTANT INFORMATION CONCERNING LIMITED WARRANTY, AND LIMITATION OF LIABILITY.

HOW TO USE THE DANIELS HX4 (M22520/5-01) CRIMP TOOL AND DIES

GENERAL INFORMATION

The DANIELS HX4 crimp tool is designed to crimp various sizes and types of ferrules, coaxial connectors, contacts, splices and terminal lugs to cables and wires. Interchangeable dies may be installed and locked in place with pins.

CAUTION: BEFORE ATTEMPTING TO REMOVE DIES FROM TOOL, ASSURE THAT ALL LOCK PINS HAVE BEEN REMOVED (SEE FIGURE 4). FAILURE TO DO SO MAY RESULT IN SERIOUS DAMAGE TO THE TOOL.

DIE INSTALLATION

1. Align die rail slots in die halves with the rail in the crimp tool and push shank of dies into holes. Dies will snap into place. (See Figure 1)
2. Close tool handle to make sure dies are properly seated. The tool is now ready for use.

DIE REMOVAL

1. With the crimp tool handle open, place die removal tool against end of knockout pin and tap gently with small hammer (See Figure 2). The die will be released from the front die holder. It can now be removed by hand.
2. Close the crimp tool handle and slide the die removal tool between the die and tool body (See Figure 3). Pull handle open with a snap action. The die will be released and can then be removed by hand.

PERMANENT DIE ASSEMBLY

1. Install dies in crimp tool.
2. Drive lock pins, supplied with dies, through holes and flush with outside surfaces. Long pin through tool body and short pin through push rod. (see Figure 4)

NOTE: Die removal tool part number HX3-82 is furnished with crimp tool. (If die removal tool is not available, a rod approximately 3/16" diameter X 1 3/4" long may be used)

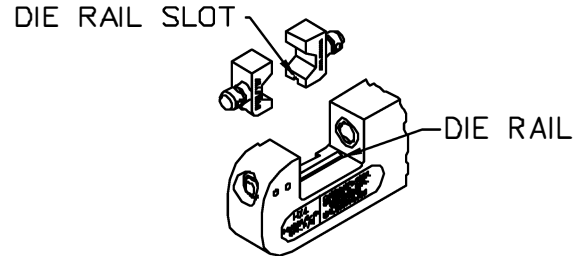

FIG. 1

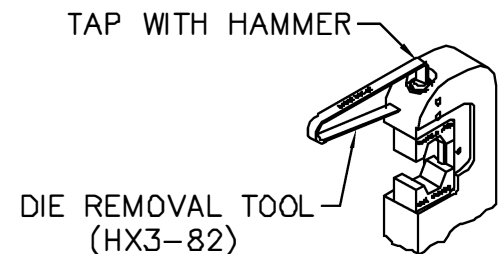

FIG. 2

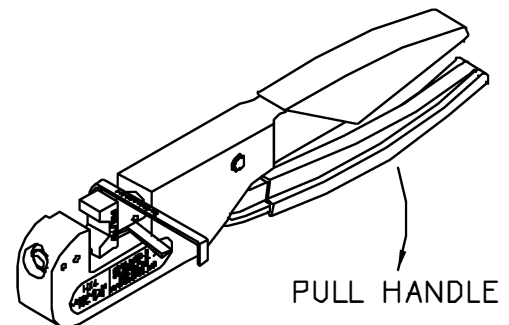

FIG. 3

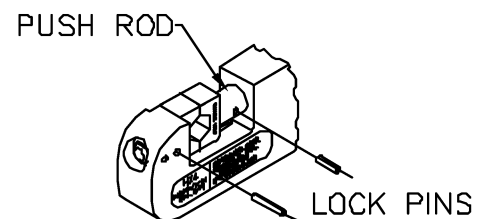

FIG. 4

NOTE: Use only "Y" series dies with HX4 crimp tool.

HEX DIE GAGING

1. Hold the tool handles firmly closed.
2. Insert the GO gage (green) member as shown; gaging only those hex flats parallel to the die face (parting line). The GO gage member should freely enter the die cavity.
3. Attempt to insert the NO-GO gage (red) member in the same manner. The NO-GO gage member may enter slightly into the die cavity, but shall not pass fully through the cavity. If the NO-GO gage member does enter the cavity fully, the die is worn and should be replaced.

CAUTION: DO NOT CRIMP THE GAGE MEMBER; TO DO SO MAY SERIOUSLY DAMAGE THE DIE SET.

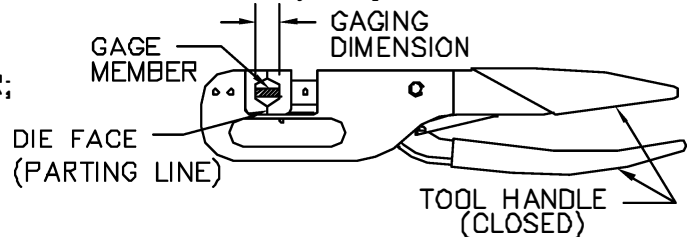

GENERAL INFORMATION

The DANIELS HX4 crimp tool features a system of interchangeable dies. There are already a wide variety of these dies, available at DANIELS, for the HX4 tool frame. As new requirements evolve, the ongoing process of developing new die sets continues.

CARE OF TOOL

We strongly recommend that you:

1. DO NOT immerse tools in cleaning solution.
 2. DO NOT spray oil into tool to lubricate.
 3. DO NOT attempt to disassemble tool or make repairs.
- This is a precision crimp tool and should be handled as such.

DMC offers complete refurbishing and recalibration services.

DMC specially engineers and manufactures complete tool kits to satisfy individual customer requirements, such as total aircraft support, general shop maintenance or production, on board ship and vehicle service, etc.

LIMITATION OF LIABILITY

DANIELS MANUFACTURING CORPORATION IS NOT LIABLE FOR CONSEQUENTIAL OR SPECIAL DAMAGES OF ANY NATURE OR KIND RESULTING FROM THE USE, OR MISUSE, OF ANY OF ITS PRODUCTS. OWNERS AND USERS OF DMC PRODUCTS ASSUME FULL RESPONSIBILITY FOR INSTRUCTING THEIR EMPLOYEES IN THE PROPER AND SAFE USE OF SUCH PRODUCTS.

LIMITED WARRANTY

DMC (Daniels Manufacturing Corporation) warrants each new product sold by it to be free from defects in material and workmanship under normal use and service. DMC's obligation under this warranty is limited to the free correction or, at DMC's option, the refund of the purchase price of any such product which proves defective in normal service within ninety (90) days after delivery to the first user, provided that the product is returned to DMC with all transportation charges prepaid and which shall appear to DMC's satisfaction, after DMC's inspection, to have been defective in material or workmanship, it being understood that DMC products are not consumer products. This warranty shall not cover any damage to any product which, in the opinion of DMC, was caused by normal wear, misuse, improper operation, tampering, neglect or accident. This warranty is in lieu of all other warranties express or implied. No warranty, express or implied, is made or authorized to be made or assumed with respect to products of Daniels Manufacturing Corporation other than those herein set forth.

Mouser Electronics

Authorized Distributor

Click to View Pricing, Inventory, Delivery & Lifecycle Information:

[Daniels Manufacturing:](#)

[M22520/5-01](#)